

2024

Connectors



目次 Table of Contents

	Page
FPC/FFC Connectors FPC/FFC コネクタ	1 - 5
Board to Board Connectors 基板対基板コネクタ	6 - 9
Hard Metric Connectors ハードメトリックコネクタ	10
Wire to Wire/Board Connectors 電線対電線（基板）コネクタ	10
Card Edge Connectors カードエッジコネクタ	11
Interface Connectors インターフェースコネクタ	11
Power Terminals 電源端子	12
Miniature Wire to Board Connectors 超小型電線対基板コネクタ	12
Shield Locks シールドロック	13
Shunt Connectors スイッチングコネクタ	13
Rack and Panel Connectors ラックアンドパネルコネクタ	14
Branch Connectors Sheltap[®] 分岐用コネクタ シェルタップ [®]	15

FPC/FFC Connectors

FPC/FFC コネクタ



日本語



English

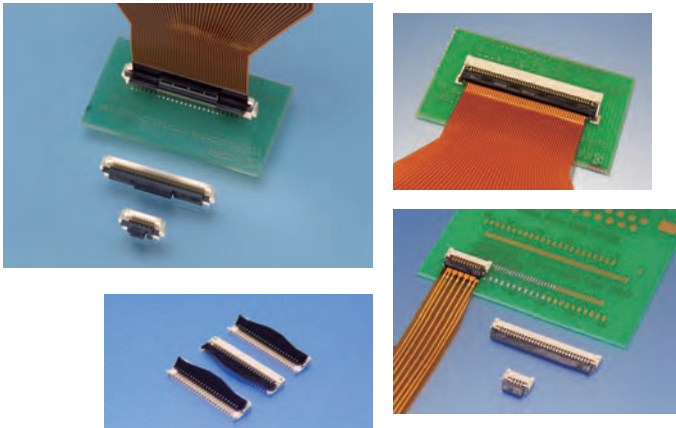

京セラの FPC/FFC 用コネクタは、高速インターフェース規格の V-by-One®HS を満足する製品や車載機器向けの耐熱性に優れた製品、小型通信機器に最適な狭ピッチ・低背の省スペース製品、使いやすいワンアクションロック、フリップロック、低価格対応の Non-ZIF 等、ご要望にお応えする幅広い製品群を取り揃えています。

FPC/FFC connectors provided by Kyocera are narrow-pitches and low-profile connectors contributing to space-saving that are optimum for compact telecommunication apparatus and products supporting equipment requiring high-speed data transmission, and a wide variety of product types featuring convenient one-touch locking function (flip-type locking), sliding ZIF or inexpensive type of Non-ZIF and etc. are provided for achieving customers' requests.

0.2mm Pitch

6866 Series

製品高さ	Profile Height	0.95mm
極数	No. of Positions	21 to 71
定格電流	Current	DC 0.2A
定格電圧	Voltage	DC 50V
耐電圧	D.W. Voltage	AC 200Vrms
FPC 厚	FPC Thickness	0.2mm
接点位置	Contact	Bottom



0.3mm Pitch

6293 Series

製品高さ	Profile Height	0.9mm
極数	No. of Positions	9 to 39
定格電流	Current	DC 0.2A
定格電圧	Voltage	DC 50V
耐電圧	D.W. Voltage	AC 200Vrms
FPC 厚	FPC Thickness	0.2mm
接点位置	Contact	Dual



6844 Series

製品高さ	Profile Height	0.95mm
極数	No. of Positions	11 to 61
定格電流	Current	DC 0.2A
定格電圧	Voltage	DC 50V
耐電圧	D.W. Voltage	AC 200Vrms
FPC 厚	FPC Thickness	0.2mm
接点位置	Contact	Bottom



6841 Series

製品高さ	Profile Height	3.6mm
極数	No. of Positions	15 to 51
定格電流	Current	DC 0.2A
定格電圧	Voltage	DC 50V
耐電圧	D.W. Voltage	AC 200Vrms
FPC 厚	FPC Thickness	0.2mm
接点位置	Contact	Single



0.4mm Pitch

6824 Series

製品高さ	Profile Height	0.93mm
極数	No. of Positions	4 to 22
定格電流	Current	AC/DC 0.4A
定格電圧	Voltage	AC/DC 50V
耐電圧	D.W. Voltage	AC 200Vrms
FPC/FFC 厚	FPC/FFC Thickness	0.3mm
接点位置	Contact	Dual



6287 Series

製品高さ	Profile Height	1.2mm
極数	No. of Positions	14 to 76
定格電流	Current	DC 0.4A
定格電圧	Voltage	DC 40V
耐電圧	D.W. Voltage	AC 200Vrms
FPC/FFC 厚	FPC/FFC Thickness	0.3mm
接点位置	Contact	Bottom



0.5mm Pitch

6277 Series

小型通信機器の液晶表示装置向けなどに開発された超低背（高さH=0.9mm）、ZIF ライトアングル、上下両面接点、省スペースタイプの FPC/FFC 用コネクタです。This series are 0.5mm pitch, ZIF, right angle, FPC connectors with dual-sided contacts. These connectors feature a low profile height of 0.9mm, and are applicable to LCDs of compact telecommunication devices.

製品高さ	Profile Height	0.9mm
極数	No. of Positions	3 to 6
定格電流	Current	DC 0.4A
定格電圧	Voltage	DC 50V
耐電圧	D.W. Voltage	AC 200Vrms
FPC/FFC 厚	FPC/FFC Thickness	0.2mm
接点位置	Contact	Dual



6298 Series

製品高さ	Profile Height	0.9 / 1.1mm
極数	No. of Positions	3 to 13
定格電流	Current	DC 0.4A
定格電圧	Voltage	DC 50V
耐電圧	D.W. Voltage	AC 200Vrms
FPC/FFC 厚	FPC/FFC Thickness	0.2mm
接点位置	Contact	Bottom



6811 Series

作業者の操作ミスや、意図しない箇所に指が触れてしまうといった誤操作に起因するコネクタの破損に着目し、堅牢性を高めた製品です。

This series possesses enhanced mechanical resiliency by implementing measures aimed at reducing breakage of connectors caused by human error in the assembly process.

製品高さ	Profile Height	1.28mm
極数	No. of Positions	4 to 32
定格電流	Current	DC 0.5A
定格電圧	Voltage	DC 50V
耐電圧	D.W. Voltage	AC 200Vrms
FPC/FFC 厚	FPC/FFC Thickness	0.3mm
接点位置	Contact	Bottom



6809 Series

製品高さ	Profile Height	0.93mm
極数	No. of Positions	4 to 40
定格電流	Current	DC 0.5A
定格電圧	Voltage	DC 50V
耐電圧	D.W. Voltage	AC 200Vrms
FPC/FFC 厚	FPC/FFC Thickness	0.3mm
接点位置	Contact	Bottom



6284 Series

製品高さ	Profile Height	1.5mm
極数	No. of Positions	5 to 30
定格電流	Current	DC 0.4A
定格電圧	Voltage	DC 50V
耐電圧	D.W. Voltage	AC 200Vrms
FPC/FFC 厚	FPC/FFC Thickness	0.3mm
接点位置	Contact	Dual



FPC/FFC Connectors

FPC/FFC コネクタ

0.5mm Pitch

6808 Series

定格電流値 4.0A/3contacts に対応しており、一般的な FPC コネクタとしての使用に加え、電源対応が可能です。

Supports rated current of DC 4.0A (3 contacts). Not only suitable for standard FPC connector use, but also battery connections.

製品高さ	Profile Height	1.5mm
極数	No. of Positions	7
定格電流	Current	DC 0.5A, DC 4.0A (3 Contacts)
定格電圧	Voltage	DC 50V
耐電圧	D.W. Voltage	AC 200Vrms
FPC/FFC 厚	FPC/FFC Thickness	0.3mm
接点位置	Contact	Dual

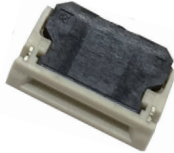

6806 Series

製品高さ	Profile Height	1.75mm
極数	No. of Positions	8 to 80
定格電流	Current	DC 0.5A
定格電圧	Voltage	DC 50V
耐電圧	D.W. Voltage	AC 200Vrms
FPC/FFC 厚	FPC/FFC Thickness	0.3mm
接点位置	Contact	Bottom



6815 Series

高精細画像を実現するための高速伝送を可能としたコネクタであり、100 極の多極を実現しました。

This Series optimizes high-speed data transmission for high-definition images and has achieved high pin counts of up to 100 pins.

製品高さ	Profile Height	1.9mm
極数	No. of Positions	81 to 100
定格電流	Current	DC 0.5A
定格電圧	Voltage	DC 50V
耐電圧	D.W. Voltage	AC 200Vrms
FPC/FFC 厚	FPC/FFC Thickness	0.3mm
接点位置	Contact	Bottom



6210 / 6212 / 6260 / 6262 Series

製品高さ	Profile Height	2.0mm
極数	No. of Positions	4 to 42
定格電流	Current	DC 0.4A
定格電圧	Voltage	DC 50V
耐電圧	D.W. Voltage	AC 200Vrms
FPC/FFC 厚	FPC/FFC Thickness	0.3mm
接点位置	Contact	Bottom (6210/6260), Top (6212/6262)

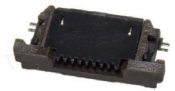

6240 Series

製品高さ	Profile Height	2.0mm
極数	No. of Positions	6 to 60
定格電流	Current	DC 0.4A
定格電圧	Voltage	DC 50V
耐電圧	D.W. Voltage	AC 200Vrms
FPC/FFC 厚	FPC/FFC Thickness	0.3mm
接点位置	Contact	Bottom



6288 Series

耳付 FPC/FFC との組み合わせで斜め挿入による接点ズレを防止、確実な接続を可能とするとともに、FPC/FFC 保持力を向上しました。

When connecting with an FPC/FFC, the displacement of contact points due to slanted cable insertion is prevented. In addition, FPC/FFC retention force is improved.

製品高さ	Profile Height	2.0mm
極数	No. of Positions	8 to 80
定格電流	Current	DC 0.4A
定格電圧	Voltage	DC 50V
耐電圧	D.W. Voltage	AC 200Vrms
FPC/FFC 厚	FPC/FFC Thickness	0.3mm
接点位置	Contact	Bottom

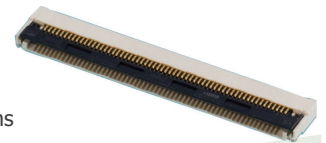

6892 Series

アクチュエータの両端に嵌合状態が確認できる窓を設置。さらに、FPC/FFC が正しく挿入されていない場合、アクチュエータがロックされない構造とすることで、目視または AOI で嵌合不具合の判別が容易になりました。

This series' design enables users to easily confirm quality assurance by both visual checks and AOI. As seen below, windows on the actuator enable users to confirm insertion status and the actuator is unable to close until the FPC/FFC is in the correct position, preventing misalignment.

製品高さ	Profile Height	2.2mm
極数	No. of Positions	30 to 68
定格電流	Current	DC 0.5A
定格電圧	Voltage	DC 50V
耐電圧	D.W. Voltage	AC 200Vrms
FPC/FFC 厚	FPC/FFC Thickness	0.3mm (Signal), 0.5mm (Ground)
接点位置	Contact	Bottom



6882 Series

製品高さ	Profile Height	2.1mm
極数	No. of Positions	10 to 61
定格電流	Current	DC 0.4A
定格電圧	Voltage	DC 50V
耐電圧	D.W. Voltage	AC 200Vrms
FPC/FFC 厚	FPC/FFC Thickness	0.3mm
接点位置	Contact	Dual



高耐熱仕様
High heat resistance



高速インターフェース規格「V-by-One®HS」(伝送可能速度: 最大 3.75Gbps) に準拠。
Complies with high-speed serial interface standards V-by-One®HS, which reaches speeds up to 3.75Gbps.

V-by-One は、ザインエレクトロニクス株式会社の登録商標です。V-by-One is a registered trademark of THINE Electronics, Inc.

0.5mm Pitch

6817 Series



FPC/FFC を挿入するだけで自動でロックがかかる作業性良好な独自のロック構造です。アクチュエータを開放状態で維持できるため、片手で FPC/FFC 抜き作業対応可能となり、作業スペースが限られた箇所へも実装することが可能です。

A unique locking structure with excellent workability that automatically locks just by inserting FPC/FFC. Since the actuator can be held open, it is possible to remove FPC/FFC with one hand, and it is also possible to mount the connector on a limited work space.

製品高さ	Profile Height	2.6mm (Right angle) / 5.32mm (Vertical)
極数	No. of Positions	10 to 50
定格電流	Current	DC 0.5A
定格電圧	Voltage	DC 50V
耐電圧	D.W. Voltage	AC 200Vrms
FPC/FFC 厚	FPC/FFC Thickness	0.3mm (Signal), 0.5mm (Ground)
接点位置	Contact	Bottom (Right angle), Single (Vertical)

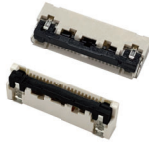

6893 Series



ロボットによる工程の自動化に対応したワンアクションタイプの 0.5mm ピッチ FPC/FFC コネクタです。作業現場にて、接触不具合の原因となる FPC/FFC に付着した異物の除去性能を向上しました。最大 125℃の耐熱で、車載機器にもご使用頂けます。

One-action type 6893 Series FPC/FFC connectors utilize a proprietary structure that enables quick, stable connections in a single insertion, removing a significant impediment to fully automated assembly. This new series offers a 2x improvement in foreign matter removal performance compared to our previous products, helping to prevent the FPC/FFC deposits that can cause contact failure after insertion. It is heat-resistant up to 125 degrees Celsius and mountable on in-vehicle devices such as HUDs, clusters, and CIDs with strict high-temperature compliance.

製品高さ	Profile Height	2.8mm
極数	No. of Positions	10 to 60
定格電流	Current	DC 0.5A
定格電圧	Voltage	DC 50V
耐電圧	D.W. Voltage	AC 200Vrms
FPC/FFC 厚	FPC/FFC Thickness	0.3mm
接点位置	Contact	Bottom

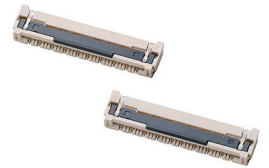

6244 Series

製品高さ	Profile Height	4.1mm
極数	No. of Positions	6 to 30
定格電流	Current	DC 0.4A
定格電圧	Voltage	DC 50V
耐電圧	D.W. Voltage	AC 200Vrms
FPC/FFC 厚	FPC/FFC Thickness	0.3mm
接点位置	Contact	Single

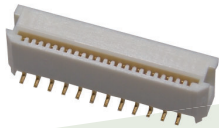

6810 Series



産業用ロボットによる工程の自動化に対応したワンアクションタイプのロック付き FPC/FFC コネクタです。独自のロック構造により、FPC/FFC を挿入する 1 つの動作（ワンアクション）だけで自動でロックがかかる良好な作業性を実現しました。

This series utilizes a proprietary structure that enables quick, stable connections in a single insertion (auto-lock), removing a significant impediment to fully automated assembly processes.

製品高さ	Profile Height	4.1mm (Right angle) / 6.0mm (Vertical)
極数	No. of Positions	10 to 60
定格電流	Current	DC 0.4A
定格電圧	Voltage	DC 50V
耐電圧	D.W. Voltage	AC 200Vrms
FPC/FFC 厚	FPC/FFC Thickness	0.3mm (Signal), 0.5mm (Ground)
接点位置	Contact	Bottom (Right angle), Single (Vertical)



6214 / 6274 Series

製品高さ	Profile Height	4.1mm (6214) / 4.4mm (6274)
極数	No. of Positions	6 to 40 (6214) / 31 to 50 (6274)
定格電流	Current	DC 0.4A
定格電圧	Voltage	DC 50V
耐電圧	D.W. Voltage	AC 200Vrms
FPC/FFC 厚	FPC/FFC Thickness	0.3mm
接点位置	Contact	Single

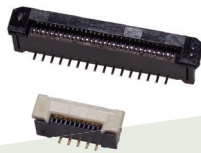

6251 Series



製品高さ	Profile Height	5.45mm
極数	No. of Positions	10 to 64
定格電流	Current	DC 0.4A
定格電圧	Voltage	DC 50V
耐電圧	D.W. Voltage	AC 200Vrms
FPC/FFC 厚	FPC/FFC Thickness	0.3mm
接点位置	Contact	Single



6801 Series



製品高さ	Profile Height	5.5mm
極数	No. of Positions	20 to 50
定格電流	Current	DC 0.4A
定格電圧	Voltage	DC 50V
耐電圧	D.W. Voltage	AC 200Vrms
FPC/FFC 厚	FPC/FFC Thickness	0.3mm
接点位置	Contact	Single



高耐熱仕様
High heat resistance



ワンアクションロック
One-action lock



高速インターフェース規格「V-by-One®HS」(伝送可能速度: 最大 3.75Gbps) に準拠。
Complies with high-speed serial interface standards V-by-One®HS, which reaches speeds up to 3.75Gbps.

V-by-One は、ザインエレクトロニクス株式会社の登録商標です。V-by-One is a registered trademark of THINE Electronics, Inc.

FPC/FFC Connectors

FPC/FFC コネクタ

1.0mm Pitch

6227 Series

製品高さ	Profile Height	2.0mm
極数	No. of Positions	4 to 20
定格電流	Current	DC 1.0A
定格電圧	Voltage	DC 50V
耐電圧	D.W. Voltage	AC 500Vrms
FPC/FFC 厚	FPC/FFC Thickness	0.3mm
接点位置	Contact	Dual



6200 / 6224 Series

製品高さ	Profile Height	2.9mm
極数	No. of Positions	5 to 30
定格電流	Current	DC 1.0A
定格電圧	Voltage	DC 50V
耐電圧	D.W. Voltage	AC 500Vrms
FPC/FFC 厚	FPC/FFC Thickness	0.3mm
接点位置	Contact	Bottom (6200), Top (6224)



6232 Series (SMT)

製品高さ	Profile Height	3.0mm (Right angle) / 5.1mm (Vertical)
極数	No. of Positions	3 to 30
定格電流	Current	DC 0.5A
定格電圧	Voltage	DC 50V
耐電圧	D.W. Voltage	AC 500Vrms
FPC/FFC 厚	FPC/FFC Thickness	0.3mm
接点位置	Contact	Top, Bottom



6232 Series (DIP)

製品高さ	Profile Height	3.0mm (Right angle) / 5.5mm (Vertical)
極数	No. of Positions	3 to 30
定格電流	Current	DC 0.5A
定格電圧	Voltage	DC 50V
耐電圧	D.W. Voltage	AC 500Vrms
FPC/FFC 厚	FPC/FFC Thickness	0.3mm
接点位置	Contact	Single



6208 Series

製品高さ	Profile Height	5.0 / 5.2 / 5.5mm
極数	No. of Positions	5 to 30
定格電流	Current	DC 1.0A
定格電圧	Voltage	DC 50V
耐電圧	D.W. Voltage	AC 500Vrms
FPC/FFC 厚	FPC/FFC Thickness	0.3mm
接点位置	Contact	Single

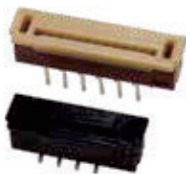

Board to Board Connectors

基板対基板コネクタ

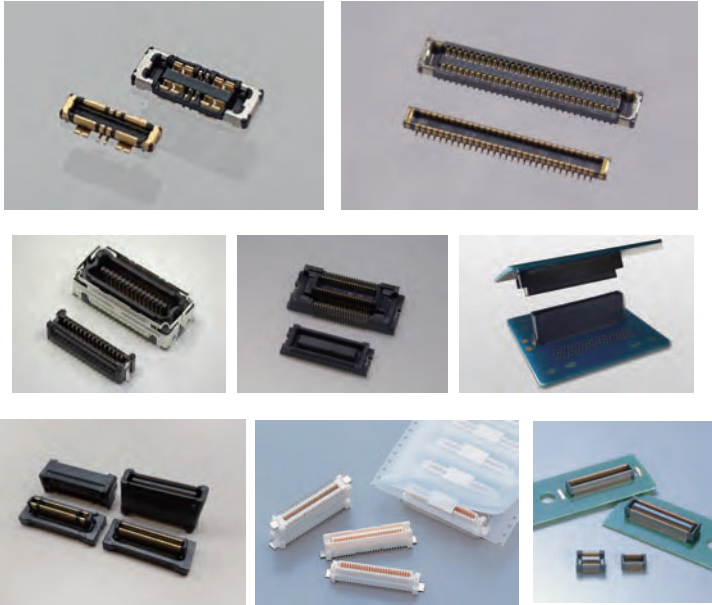

京セラの基板対基板コネクタは、スマートフォンやウェアラブルデバイスなどの小型機器に最適な 0.35mm ピッチの狭ピッチ・低背・省スペース製品から、自動車や医療機器など高い接触信頼性を要求される機器に最適な基板実装のズレや振動を吸収するフローティング構造を採用した製品など豊富なバリエーションを取り揃えています。振動や落下衝撃に強い独自の「挟み込み接点形状」（2点接点）や集中荷重を上げて異物を排除（ワイピング効果）する機構など高い接触信頼性を実現したシリーズも準備しています。

Kyocera provides a wide variety of board-to-board connectors: narrow pitches as small as 0.35mm, low profiles, and space-saving types that are best suited for compact devices such as smartphones and wearable devices. Some include a floating structure that absorb vibrations and minor misalignments on a printed circuit board for increased mating tolerances. These are best suited for automotive equipment and medical devices requiring high contact reliability. We also provide products featuring our proprietary "pinching shape" (dual-contact type) that are resistant to vibration and drop impacts, and achieves improved signal reliability upon mating with a contact structure that disperses foreign matter using concentrated loads (Wiping effect).

0.35mm Pitch

5861 Series



両端を金具で覆うことにより破損を防ぎ、高い堅牢性と滑らかな嵌合誘い込みを実現したコネクタです。また両端の金具は、定格電流 5A/ 金具で大電流通電が可能です。With metal covering both ends, these connectors realize high structural resilience, and a smooth guiding function during mating. The metal on both ends also enable them to carry a large rated current of 5A.

嵌合高さ	Stacking Height	0.6mm
幅	Width	1.95mm
極数	No. of Positions	6 to 60
定格電流	Current	DC 0.5A (~40 pin) DC 0.3A (42 pin~) DC 5.0A (Metal tab)
定格電圧	Voltage	DC 60V
耐電圧	D.W. Voltage	AC 250Vrms

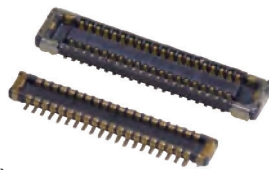

7129 Series



10A の高電流通電が可能で、バッテリーの充電時間短縮に貢献します。Capable of conducting high current up to 10A in smartphones which contributes to reduced charging time of devices.

嵌合高さ	Stacking Height	0.7mm
幅	Width	2.2mm
極数	No. of Positions	2 / 4 (Signal) 4 (Power)
定格電流	Current	DC 0.4A (Signal) DC 10A (2 Power Contacts)
定格電圧	Voltage	DC 30V
耐電圧	D.W. Voltage	AC 250Vrms



堅牢金具付
Robust type



金具通電可能
Metal tab Power

Board to Board Connectors

基板対基板コネクタ

0.35mm Pitch

5863 Series



嵌合高さ	Stacking Height	0.8mm
幅	Width	2.3mm
極数	No. of Positions	40 to 60
定格電流	Current	DC 0.3A DC 5.0A (Metal tab)
定格電圧	Voltage	DC 60V
耐電圧	D.W. Voltage	AC 250Vrms

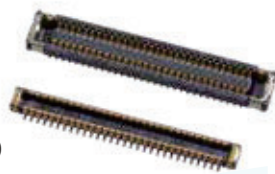

5897 Series



コネクタの内側を金具で覆うことにより強度を高めた製品です。
It is a product with high strength by covering the inside of the connector with metal fittings.

嵌合高さ	Stacking Height	0.8mm
幅	Width	2.3mm
極数	No. of Positions	78
定格電流	Current	DC 0.3A DC 3.0A (Metal tab)
定格電圧	Voltage	DC 50V
耐電圧	D.W. Voltage	AC 250Vrms



5843 Series

嵌合高さ	Stacking Height	0.8 / 1.0 / 1.5mm
幅	Width	2.4mm
極数	No. of Positions	10 to 48
定格電流	Current	DC 0.3A
定格電圧	Voltage	DC 60V
耐電圧	D.W. Voltage	AC 250Vrms

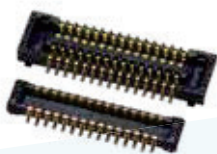

0.4mm Pitch

5804 Series

コネクタ裏面は絶縁の底壁を形成しコンタクトの露出をなくすことで、基板配線設計の自由度を向上しています。また、3種類の高さバリエーションでお客様のニーズに応えます。

嵌合高さ	Stacking Height	0.9 / 1.5 / 2.0mm
幅	Width	2.4mm
極数	No. of Positions	10 to 70
定格電流	Current	DC 0.3A
定格電圧	Voltage	DC 50V
耐電圧	D.W. Voltage	AC 250Vrms



5806 Series

嵌合高さ	Stacking Height	0.6mm
幅	Width	1.9mm
極数	No. of Positions	10 to 60
定格電流	Current	DC 0.3A
定格電圧	Voltage	DC 60V
耐電圧	D.W. Voltage	AC 250Vrms

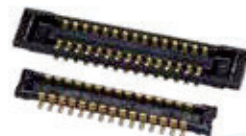

5807 Series

嵌合高さ	Stacking Height	0.7mm
幅	Width	1.9mm
極数	No. of Positions	10 to 60
定格電流	Current	DC 0.3A
定格電圧	Voltage	DC 50V
耐電圧	D.W. Voltage	AC 250Vrms



8152 Series FloXY



嵌合高さ	Stacking Height	3.5mm
幅	Width	4.3mm
極数	No. of Positions	20 to 40
定格電流	Current	DC 0.3A
定格電圧	Voltage	DC 30V
耐電圧	D.W. Voltage	AC 250Vrms
フローティング量	Floating	XY±0.4mm



5846 Series

嵌合高さ	Stacking Height	3.0mm
極数	No. of Positions	20 to 80
定格電流	Current	DC 0.4A
定格電圧	Voltage	DC 50V
耐電圧	D.W. Voltage	AC 250Vrms

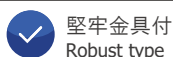

堅牢金具付
Robust type



金具通電可能
Metal tab Power



高耐熱仕様
High heat resistance



フローティング構造
Floating type

FloXYは京セラの登録商標です。
FloXY is a registered trademark of Kyocera Corporation.

0.5mm Pitch

5046 Series

嵌合高さ	Stacking Height	3.0 / 3.5 / 4.0 / 4.5mm
極数	No. of Positions	20 to 120
定格電流	Current	AC/DC 0.4A
定格電圧	Voltage	AC/DC 50V
耐電圧	D.W Voltage	AC 500Vrms

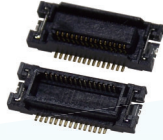

5047 Series

嵌合高さ	Stacking Height	5.0 / 7.0mm
極数	No. of Positions	20 to 100
定格電流	Current	AC/DC 0.4A
定格電圧	Voltage	AC/DC 50V
耐電圧	D.W Voltage	AC 500Vrms



5655 Series FloXY

嵌合高さ 4mm の低背を実現したフローティング機構付きの基板対基板コネクタです。2点接点構造による高い接触信頼性と、金具形状による高い堅牢性を実現しました。また、高速伝送規格 MIPI D-PHY (2.5Gbps) にも準拠しています。

This is Board to Board Connector featuring the floating structure and achieving a low-profile that is 4mm of the stacking height, which obtains high contact reliability due to the dual-contacting structured contacts and great robustness due to the shape of anchoring metals. It has high heat resistance of up to 125°C and complies with the high-speed transmission standard MIPI D-PHY (2.5 Gbps).

嵌合高さ	Stacking Height	4.0 to 7.0mm
極数	No. of Positions	10 to 100
定格電流	Current	DC 0.7A DC 3A (Power pin)
定格電圧	Voltage	DC 50V
耐電圧	D.W Voltage	AC 500Vrms
フローティング量	Floating	XY ±0.5mm



5656 Series FloXY

嵌合状態で XY 方向に ±1.0mm 可動して基板実装のスズや振動を吸収するフローティング構造をプラグコネクタに採用し、2点接点構造と合わせ接触信頼性を向上しています。125°Cまでの高耐熱対応で、カーナビやミリ波レーダー等の車載機器に適しています。

The floating structure of these connectors (plug) has a movable range of ±1.0mm in the X and Y directions, thus improving contact reliability against misalignments in mating or vibrations. Furthermore, these products can withstand high temperatures up to 125°C and are ideal for automotive equipment such as car navigation systems and millimeter-wave radars.

嵌合高さ	Stacking Height	基板平行接続 Parallel : 8.0 to 25.0mm 基板垂直接続 Vertical
極数	No. of Positions	20 to 60
定格電流	Current	DC 0.5A
定格電圧	Voltage	DC 50V
耐電圧	D.W Voltage	AC 250Vrms
フローティング量	Floating	XY ±1.0mm

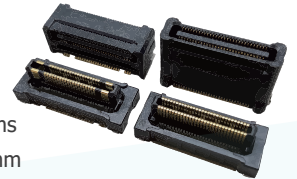

5652 Series FloXY HS

高速伝送と高い信頼性を兼ね備えたフローティング機構付き基板対基板コネクタです。16Gbpsの高速伝送を実現しながら、X,Y方向に±0.85mm可動します。

This is Board to Board Connector with a floating mechanism that achieves both high-speed transmission and high reliability.

嵌合高さ	Stacking Height	14.0 to 30.0mm
極数	No. of Positions	10 to 180
定格電流	Current	DC 0.6A DC 3A (Power pin)
定格電圧	Voltage	DC 50V
耐電圧	D.W Voltage	AC 500Vrms
フローティング量	Floating	XY ±0.85mm
High-speed transmission standard		PCIe Gen.1 to Gen.4, MIPI D/C-PHY SATA3.0, USB3.1 Gen.1



0.635mm Pitch

5689 Series FloXY

嵌合高さ	Stacking Height	8.0mm
極数	No. of Positions	40
定格電流	Current	DC 0.5A
定格電圧	Voltage	DC 100V
耐電圧	D.W Voltage	AC 500Vrms
フローティング量	Floating	XY ±0.5mm

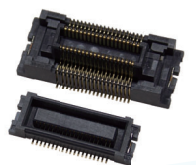

Board to Board Connectors

基板対基板コネクタ

0.8mm Pitch

5600 Series

嵌合高さ	Stacking Height	基板垂直接続 Vertical
極数	No. of Positions	30 to 140
定格電流	Current	AC/DC 0.5A
定格電圧	Voltage	AC 200V / DC 300V
耐電圧	D.W. Voltage	AC 500Vrms



1.0mm Pitch

5015 Series

産業用コンピュータ、産業用機械に搭載される、VMEバス、ホスト基板のアプリケーションの規格である、IEEE P-1386 Common Mezzanine Card Standardをサポートする基板対基板コネクタです。

This series of board-to-board connectors support the IEEE P-1386 standard for mezzanine card installations in industrial computer applications, including the VME bus, Future bus, CompactPCI bus and other host systems.

嵌合高さ	Stacking Height	8 to 15mm
極数	No. of Positions	64
定格電流	Current	AC/DC 1.0A (5 Contacts)
定格電圧	Voltage	AC/DC 250V
耐電圧	D.W. Voltage	AC 250Vrms



5077 Series

嵌合高さ	Stacking Height	基板平行接続 8 to 12mm
極数	No. of Positions	30 to 50
定格電流	Current	AC/DC 0.5A
定格電圧	Voltage	AC/DC 100V
耐電圧	D.W. Voltage	AC 500Vrms



2.54mm Pitch

9072 Series

嵌合高さ	Stacking Height	12 / 15 / 18 / 20mm
極数	No. of Positions	20 to 60
定格電流	Current	AC/DC 3A
定格電圧	Voltage	AC/DC 300V
耐電圧	D.W. Voltage	AC 650Vrms



Hard Metric Connectors

ハードメトリックコネクタ

京セラの Multi Line Module コネクタは国際規格 IEC61076-4-101 に完全合致し開発された 2.0mm ピッチ HM(Hard Metric) コネクタです。高速伝送を目的とした電磁界設計を盛り込みコネクタのライン当りの伝送レートを高める事により機器の高密度実装を実現し、省スペースと情報処理の高速化に貢献します。

Our Multi-Line Module connectors have a 2mm pitch HM (Hard Metric) design, and developed to conform completely to the global standards IEC61076-4-101. These contribute to achieve space savings and the acceleration of data processing.

8071 Series



極間隔	Pitch	2.0mm Grid
極数	No. of Positions	20 to 175
定格電流	Current	AC/DC 1.0A
定格電圧	Voltage	AC/DC 250V
耐電圧	D.W. Voltage	AC 750Vrms

8072 Series

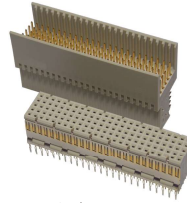

極間隔	Pitch	2.0mm Grid
極数	No. of Positions	30 / 55 / 95 / 110 / 125
定格電流	Current	AC/DC 1.0A
定格電圧	Voltage	AC/DC 250V
耐電圧	D.W. Voltage	AC 750Vrms

8073 Series

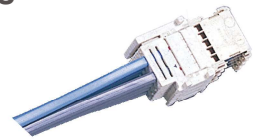

極間隔	Pitch	2.0mm
極数	No. of Positions	35 / 42
定格電流	Current	AC/DC 1.0A
定格電圧	Voltage	AC/DC 250V
耐電圧	D.W. Voltage	AC 750Vrms
適応電線	Wire size	AWG #26 to 30

Wire to Wire/Board Connectors

電線対電線（基板）コネクタ

2.0mm Pitch

8042 Series

次世代電力流量計向けに開発されたジャンパ線用電線対基板コネクタです。電線の圧着や圧接工程を必要とせず、被覆をストリップしたジャンパ線を直接嵌合することで組立作業の簡略化を実現した電線対基板用コネクタです。

This series of jumper-cable to board connectors were developed for next-generation smart meters, for which demand has been rapidly increasing in recent years. Crimping or pressure welding is unnecessary, thus assembly work is simplified by connecting stripped jumper cables directly.

極数	No. of Positions	2 to 13
定格電流	Current	DC 2.0A
定格電圧	Voltage	DC 150V
耐電圧	D.W. Voltage	AC 500Vrms
適用電線	Wire size	AWG #26



2.54mm Pitch

9021 Series

高温多湿の過酷な気象条件に耐えられることを目標に開発した高密度、高信頼性、多様性を有するコネクタです。

A high-density, multi-purpose, versatile model developed to withstand severe operating environments under high temperature and humidity.

極数	No. of Positions	2 to 20 (Single) 14 / 20 / 26 / 30 / 40 (Dual)
定格電流	Current	AC/DC 2.5A
定格電圧	Voltage	AC/DC 250V
耐電圧	D.W. Voltage	AC 750Vrms
適用電線	Wire size	AWG #22 to 28

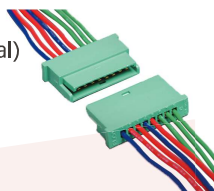

Card Edge Connectors

カードエッジコネクタ

PCIe M.2

6411 Series

PCI-SIGにより規格化された PCI Express® M.2 に準拠したコネクタです。当社では、PCI Express® M.2 コネクタを、規格の提案・策定段階から開発を開始し、高さバリエーションと各種カードモジュール用のキーイングを幅広く取り揃えました。

This series is compatible with the PCI-SIG and PCI Express® M.2 specifications. Various heights are available in both single and double-sided modules. Furthermore, midplane types featuring very low profiles are available, achieved by cutting into the printed circuit boards.

極間隔	Pitch	0.5mm
極数	No. of Positions	67
定格電流	Current	AC/DC 0.4A
定格電圧	Voltage	AC/DC 50V
耐電圧	D.W. Voltage	AC 300Vrms

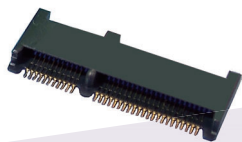

PCI Express は、PCI-SIG の商標または登録商標です。
PCI Express is a trademark or registered trademark of PCI-SIG.

Interface Connectors

インターフェイスコネクタ

SATA

SATA 5650 Series 7 Pos.

極数	No. of Positions	7
極間隔	Pitch	1.27mm
定格電流	Current	DC 1.5A
定格電圧	Voltage	DC 30V
耐電圧	D.W. Voltage	AC 500Vrms

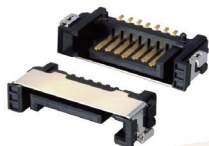

Slim line SATA 5650 Series 13 Pos.

極数	No. of Positions	13
極間隔	Pitch	1.27 / 1.0mm
定格電流	Current	DC 1.5A
定格電圧	Voltage	DC 30V
耐電圧	D.W. Voltage	AC 500Vrms

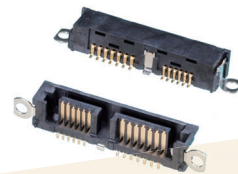

SATA 5650 Series 22 Pos.

極数	No. of Positions	22
極間隔	Pitch	1.27mm
定格電流	Current	DC 1.5A
定格電圧	Voltage	DC 30V
耐電圧	D.W. Voltage	AC 500Vrms

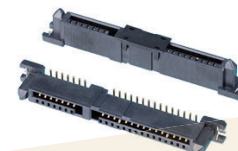

Power Terminals

電源端子

9069 Series

基板への電力供給用の端子ブロック、当社独自のプレスフィット接続により、半田付け不要。ケーブルはネジにより取り付け可能です。

Terminal blocks for supplying power to boards, which use KYOCERA's own press-fit connections that require no soldering. Cables can be screw-mounted.

極数	No. of Positions	6 / 8 / 10
極間隔	Pitch	3.18mm (6 pos.) / 2.54mm (8, 10 pos.)
定格電流	Current	AC/DC 18A (6 pos.) AC/DC 24A (8 pos.) AC/DC 30A (10 pos.)
適用ネジ	Applicable Screw	M4



Miniature Wire to Board Connectors

超小型電線対基板コネクタ

0.9mm Pitch

8041 Series

業界最低背クラス^(※)H=0.9mmを実現。従来の自社製品（8040シリーズ）に比べ、面積比 約 1/3、体積比 約 1/2 の省スペース化を実現。

^(※) 小型電線対基板コネクタにおいて（2023年9月当社調べ）

Kyocera has achieved one of the lowest mating heights in the industry* at just 0.9mm. In addition, this series realizes space-saving of approximately 1/3 in area and 1/2 in volume compared with the conventional 8040 Series.

* Based on research by Kyocera, as of September 2023.

極数	No. of Positions	2
定格電流	Current	DC 1.0A
定格電圧	Voltage	DC 30V
耐電圧	D.W. Voltage	AC 500Vrms
適用電線	Wire size	AWG #32

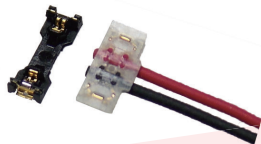

1.0mm Pitch

8040 Series

極数	No. of Positions	2
定格電流	Current	DC 1.0A
定格電圧	Voltage	DC 30V
耐電圧	D.W. Voltage	AC 500Vrms
適用電線	Wire size	AWG #32

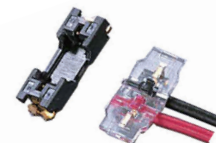

1.27mm Pitch

8005 Series

極数	No. of Positions	2
定格電流	Current	DC 1.0A
定格電圧	Voltage	DC 30V
耐電圧	D.W. Voltage	AC 500Vrms
適用電線	Wire size	AWG #32



Shield Locks

シールドロック

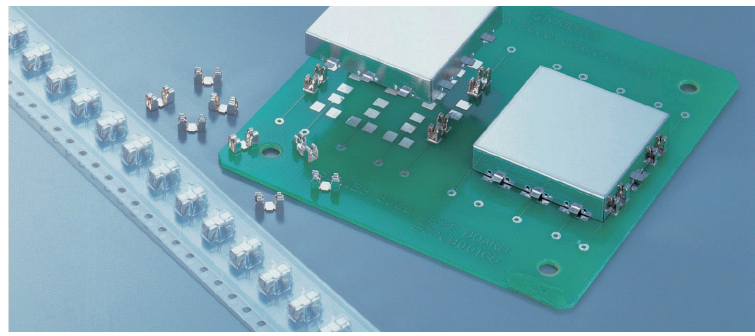

デジタルメディア製品の機器内部に使用されているシールドケースを固定するために開発された小型端子です。この製品を使用することにより、従来手付け半田により行われていたシールドケースの取付け作業が、ワンタッチで行うことが可能となります。

This series are small terminals called Shield Locks, developed to fix shield cans inside digital media sensitive to EMI. The use of Shield Locks simplifies the attachment of shield cans by allowing one-touch operation, which is conventionally carried out by manual soldering.

8069 Series

製品高さ	Height	1.8 / 3.0mm
定格電流	Current	AC/DC 0.5A
定格電圧	Voltage	AC/DC 5V
適応ケース厚	Thickness	0.2mm



Shunt Connectors

スイッチングコネクタ

2.54mm Pitch

8261 Series (DIP)

極間隔	Pitch	2.54×2.54mm
極数	No. of Positions	1 to 10 (1列, 1 row) 2 to 20 (2列, 2 row) 3 to 24 (3列, 3 row)
定格電流	Current	AC/DC 3.0A
定格電圧	Voltage	AC/DC 250V
耐電圧	D.W. Voltage	AC 750Vrms

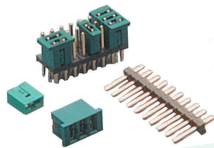

8261 Series (SMT)

極間隔	Pitch	2.54×2.54mm
極数	No. of Positions	4 to 20 (2列, 2 row)
定格電流	Current	AC/DC 3.0A
定格電圧	Voltage	AC/DC 250V
耐電圧	D.W. Voltage	AC 750Vrms

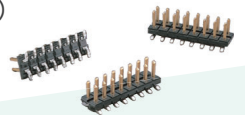

Rack and Panel Connectors

ラックアンドパネルコネクタ

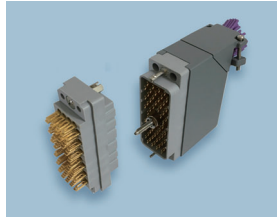
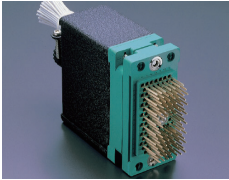

京セラが開発したオス・メス同型のコンタクトを使用した高信頼性のI/O用角型コネクタです。一対のフォーク状のコンタクトが十字形に嵌合し、4面で接触するという開発当画面期的なもので、なめらかな嵌合面と大きなワイピングアクション面をつくりだすことを可能にしました。開発以来半世紀以上使用され続けているロングセラー製品です。

Highly-reliable square-shaped I/O connectors adopting contacts developed by Kyocera where the plug and receptacle contacts are the same shape. The contacts were innovative when the Connector was developed, in which a pair of fork-shaped contacts mated in a cross-shape realizing a four-face contact, which enabled smooth mating faces and large wiping surfaces. These products have been adopted for more than half a century since they were first developed.

8016 Series

ネジの回転によって嵌合を行うアクチュエーティングスクリュー機構で、嵌合時のコネクタに方向性をもたせるとともに誤嵌合を防止するガイドピンソケットなど、独自の設計となっています。結線方法は、圧着、はんだ付、ワイヤーラッピングから選択可能です。

The structure is uniquely designed to contain the actuating screw mechanism to ensure a tight fit by the screw thread, and the guide pin and socket orienting the connector to prevent incorrect fittings. Available in crimp, tab soldering, and wire wrapping types.

極間隔	Pitch	3.81 × 3.81 / 3.81 × 3.30mm
極数	No. of Positions	20 / 38 / 56 / 90 / 120
定格電流	Current	AC/DC 8.5A (10 Contacts)
定格電圧	Voltage	AC 250V
耐電圧	D.W. Voltage	AC 1,250Vrms

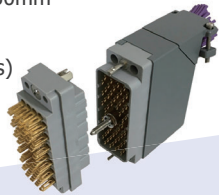

8027 Series

極間隔	Pitch	6.35 × 6.35mm
極数	No. of Positions	30
定格電流	Current	AC/DC 6.0A
定格電圧	Voltage	AC 500V
耐電圧	D.W. Voltage	AC 2,500 Vrms



8017 Series

極間隔	Pitch	1.91 × 3.81mm
極数	No. of Positions	75 / 100 / 130
定格電流	Current	AC/DC 8.5A (10 Contacts)
定格電圧	Voltage	AC 250V
耐電圧	D.W. Voltage	AC 1,500Vrms

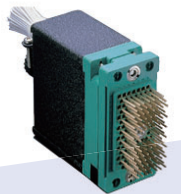

8014 Series

極間隔	Pitch	4.0 × 4.0mm
極数	No. of Positions	50 / 64
定格電流	Current	AC/DC 2.0A
定格電圧	Voltage	AC 125V / DC 110V
耐電圧	D.W. Voltage	AC 2,000Vrms



Branch Connectors Sheltap®

分岐用コネクタ シェルタップ®

用途 Application

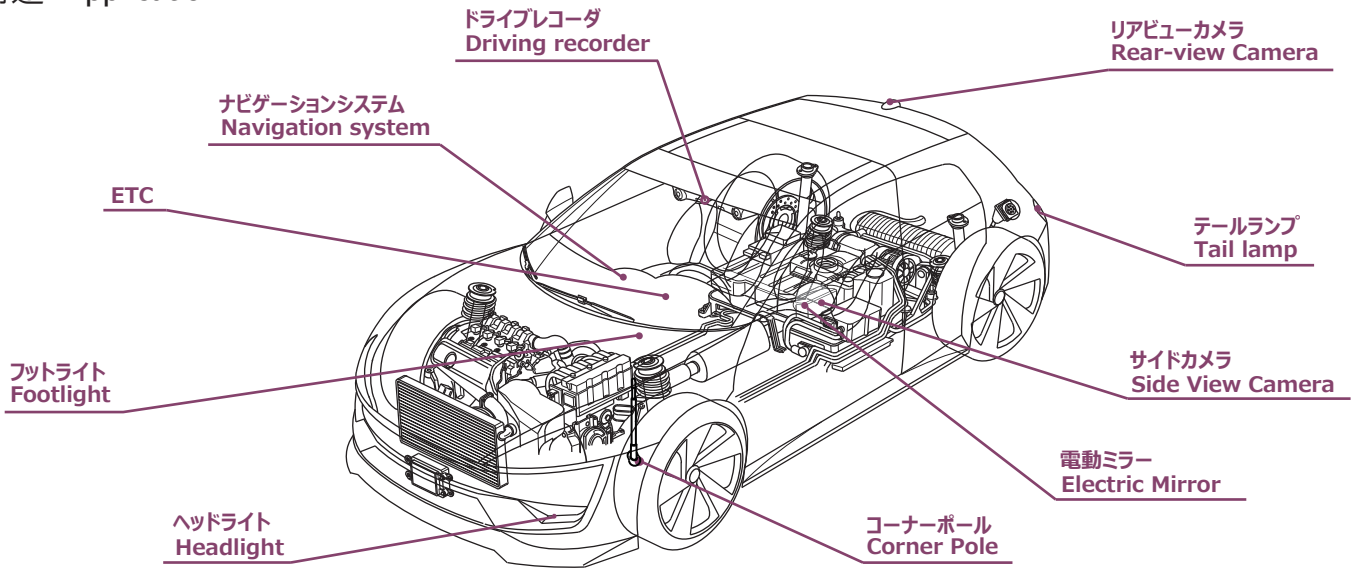

電線分岐コネクタシリーズの製品ブランド。二枚貝（Shell）のように、ヒンジ部を折り曲げることで、容易に結線できる優れた作業性と、自動車市場で求められる高い信頼性を実現した製品群。

Kyocera's Sheltap series of branch-style electronic connectors are engineered for automotive use. The clamshell design allows Sheltap connectors to branch and distribute electricity easily and with long-term reliability, even in harsh environments.

自動車用アフターパーツを追加する際に、一般工具にて簡単に取り付けが出来る回路分岐用コネクタ群です。メインハーネスから電装部品側ハーネスを直接分岐し、メインハーネスのどの部分からでも分岐が可能で作業性に優れている製品です。

These series are branch connectors designed for easy attachment of additional parts for automobiles by use of pliers. These products enable the main wire harness to branch into the electrical component side when attaching the additional parts. Any part of the main wire harness is available to branch, which contributes to great workability.

9715 Series

9715 は独自のハウジングロック構造とシール材の組み合わせで、自動車部品ワイヤハーネスコネクタの試験方法「JASO D616」の高圧洗浄や高温放置試験などの条件をクリアし、高い防水性と信頼性を実現しました。

By combining a unique housing lock structure with sealant materials, the new connectors are able to meet JASO D616 standards for high waterproofing and reliability in automotive components.

定格電流	Current	Aluminum Wire : AC/DC 8.0A (0.5sq), AC/DC 9.0A (0.75sq)
		Copper Wire : AC/DC 9.0A (0.5sq)
定格電圧	Voltage	AC/DC 125V
耐電圧	D.W. Voltage	AC 1,000Vrms
適応電線	Wire size	Aluminum Wire : 0.5 / 0.75sq Copper Wire : 0.5sq

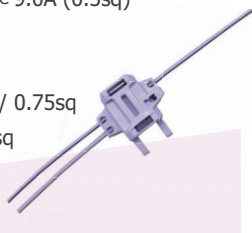

9215 Series

定格電流	Current	Aluminum Wire : AC/DC 9.0A Copper Wire : AC/DC 3.0A (0.13sq), AC/DC 8.0A (0.3sq), AC/DC 10A (0.5 / 0.85sq)
定格電圧	Voltage	AC/DC 125V
耐電圧	D.W. Voltage	AC 1,000Vrms
適応電線	Wire size	Aluminum Wire : 0.5 / 0.75sq Copper Wire : 0.13 / 0.3 / 0.5 / 0.85sq

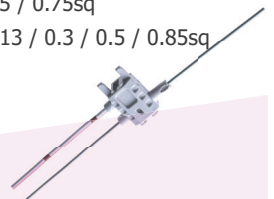

「Sheltap」および「シェルタップ」は、京セラの登録商標です。
"Sheltap" is a trademark of Kyocera Corporation, registered in Japan and other countries.

カタログご使用上の注意事項 Notes for Using this Catalog

1. カタログの記載内容は参考仕様です。製品の仕様については正式に取り交わした仕様書に基づくものとします。
2. 本カタログの記載内容は、製品の改良等のために予告なく変更する場合がございます。ご使用に際しては最新の情報をご確認ください。また、当社製品カタログは原則として毎年更新されます。旧版カタログでのご要望については応じられない場合がありますのでお問い合わせください。
3. 本カタログに記載されている製品は一般電子機器（情報機器、通信機器、音響映像機器、計測機器、家電製品等）に使用されることを意図しています。特別な品質・信頼性が要求され、その故障や誤動作が直接人命を脅かしたり、人体に危害を及ぼす恐れのある装置やシステム（交通機器、安全装置、航空・宇宙用、原子力制御、生命維持装置を含む医療機器など）にご使用をお考えのお客様は、必ず事前に当社販売窓口までご相談ください。
4. 当社は品質・信頼性の向上に努めておりますが、万が一に備え、装置やシステム上で十分な安全設計をお願いします。
5. 設計に際しては最大定格、動作電源電圧、動作温度など保証範囲内でお使いください。保証値を超えての使用など、本カタログに記載する製品の誤った使用または不適切な使用などに起因する製品の運用結果につきましては、当社は責任を負いかねますので、ご了承ください。
6. 本カタログに記載された動作概要および回路例は、製品の標準的な動作や使用方法を説明するためのものです。したがって、製品を使用される場合には、外部諸条件を十分考慮のうえ、回路・実装設計を行ってください。
7. 本カタログに記載された技術情報は製品の代表的動作・応用を説明するためのもので、その使用に際しての当社及び第三者の知的財産権その他の権利に対する保証または許諾を行うものではありません。
8. 本カタログで使用される商標、ロゴ、商号に関する権利は、当社またはそれぞれの権利の所有者に帰属します。
9. 本カタログに記載されている製品のうち、外国為替及び外国貿易法に定める規制対象貨物・役務の輸出に際しては、同法に基づく輸出許可・承認が必要です。
10. 本カタログの記載内容を当社の許可無く転載・複写することを禁止いたします。

1. Specifications described in this catalog are for reference. Specifications shall be based on written documents agreed by each party.
2. Contents in this catalog are subject to change without notice. It is recommended to confirm the latest information at the time of usage. Also, this catalog is revised once a year. We may not be able to accept requests based on old catalogs.
3. Products in this catalog are intended to be used in general electronic equipment such as office equipment, audio and visual equipment, communication equipment, measurement instrument and home appliances. It is absolutely recommended to consult with our sales representatives in advance upon planning to use our products in applications which require extremely high quality and reliability such as aircraft and aerospace equipment, traffic systems, safety systems, power plant and medical equipment including life maintenance systems.
4. Even though we strive for improvements of quality and reliability of products, it is requested to design with enough safety margin in equipment or systems in order not to threaten human lives directly or damage human bodies or properties by an accidental result of products.
5. It is requested to design based on guaranteed specifications for such as maximum ratings, operating voltage and operating temperature. It is not the scope of our guarantee for unsatisfactory results due to misuse or inadequate usage of products in the catalog.
6. Operation summaries and circuit examples in this catalog are intended to explain typical operation and usage of the product. It is recommended to perform circuit and assembly design considering surrounding conditions upon using products in this catalog.
7. Technical information described in this catalog is meant to explain typical operations and applications of products, and it is not intended to guarantee or license intellectual properties or other industrial rights of the third party or Kyocera.
8. Trademarks, logos and brand names used in this catalog are owned by Kyocera or the corresponding third party.
9. Certain products in this catalog are subject to the Foreign Exchange and Foreign Trade Control Act of Japan, and require the license from Japanese Government upon exporting the restricted products and technical information under the law. Besides, it is requested not to use products and technical information in the catalog for the development and/or manufacture of weapons of mass destruction or other conventional weapons, nor to provide them to any third party with the possibility of having such purposes.
10. It is prohibited to reprint and reproduce a part or whole of this catalog without permission.

